

# **DOMINATOR** **SERIES**

## **Domestic Hot Water Heaters and Boilers**



**RBI**<sup>®</sup>  
RELIABLE. BOLD. INNOVATIVE.

# DOMINATOR SERIES

## High Performance Boilers and Water Heaters

The Dominator® Series from RBI offers superior performance and serviceability in a near-condensing high efficiency, multi-stage boiler. At the heart of the unit is a sealed combustion chamber that provides the flexibility of using outside air or mechanical room air for combustion. The chamber design, with fan-assist, multi-speed blowers and state-of-the-art staging control, offers high efficiency staged firing in a compact package and virtually eliminates heat loss. The Dominator incorporates all the latest technological advances that engineers, contractors, and building owners look for when specifying boilers and water heaters.

### Standard Equipment

- Finned Copper Tube Heat Exchanger – Two-Pass
- Mounted & Wired Flow Switch
- FM Compliant Gas Train
- Sealed Combustion Chamber
- Mounted ASME Relief Valve
- Pump Delay Control
- Factory Fired Tested
- Barometric Damper – Category 1
- Galvalume® Metal Jacket (Indoor/Outdoor)

### Dependable, Efficient Performance

- Up to 85% Efficient
- Uginox Alloy Stainless Steel Burners
- Glass Lined Headers
- 2 or 4-Stage Firing Modes (300 On/Off Only)
- Category I & III Venting



Dominator Series boilers and water heaters are standard with corrosion-resistant galvanized steel jacket with Galvalume finish ideal for outdoor or indoor installations.

### Easy to Install and Service

- Slide-Out Heat Exchanger
- Side Intake, All Sizes
- Rear Intake, Sizes 750-2100
- Stackable Frame (Seismic Approval up to Zone 4)
- Field Reversible Headers
- Low Voltage Controls
- Direct Vent (up to 35' Equivalent)

### Optional Features

- Bronze Headers
- Cupro-Nickel Finned Tubes
- Outdoor Installation
- Freeze Protection Package
- Thru-Wall Venting
- CSD-1 Compliant Gas Train and Controls

## Load Matching Staged Firing

Unlike most non-condensing units that are limited to only two-stage firing, the Dominator provides up to four-stages of firing, allowing the boiler/water heater to more closely match the heating load. The Dominator utilizes the most advanced Proportional Integral Derivative (P.I.D.) sequencing control on the market to accurately control the staging of the units. The control has six modes of operation that can be field set, with built-in standard features that are options on most competitive units. These standard features include outdoor reset and pump delay on temperature differential between the supply and return temperatures of the unit.



\*Pool heater applications available in non-U.S. markets only.

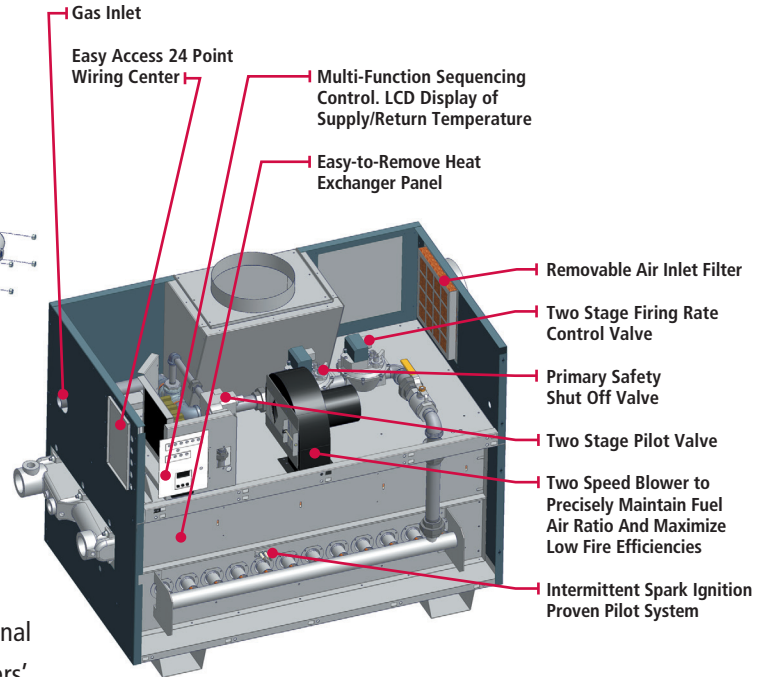
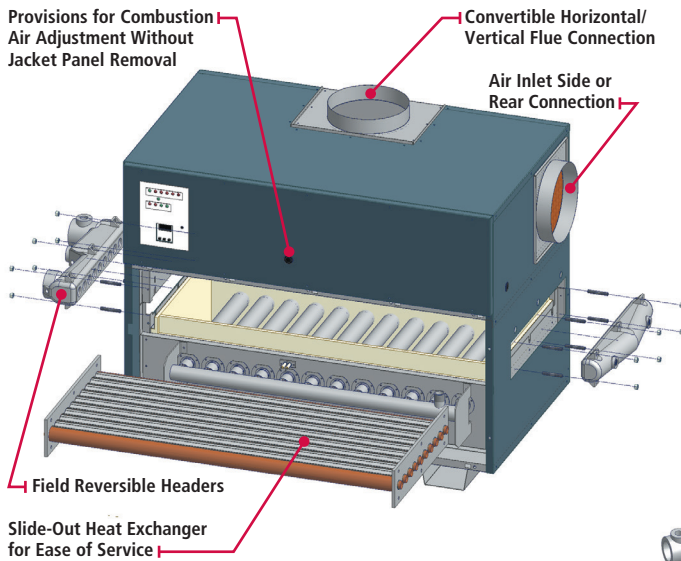

## Proven Pilot Ignition System

The unique pilot ignition is safer and more reliable than traditional hot surface systems (HSI) commonly used on other manufacturers' equipment. The system employs a burner tube as a pilot. Gas is injected into a single burner and ignited by spark. A flame rod then monitors the pilot tube flame. Once the pilot is proven the main gas valves are powered and the remaining burner tubes are safely lit. This proven system offers greater dependability and is superior to fragile HSI systems that can require frequent replacement.

## “Smart Service” Design

Ease of installation and service are trademarks of all RBI water heaters and boilers. Critical components are fully accessible to make short work of service and maintenance calls. The Dominator is the only sealed combustion chamber boiler/water heater with time-saving service features including a slide-out control cabinet for easy access to wiring and a slide-out heat exchanger for less time-consuming service and repair. And the Dominator is only 29.5" wide to fit easily through standard doorways.

## Quality Construction for Dependable Performance

The Dominator features a robust, compact design using high quality materials for dependable performance. From our stainless steel burn tubes to our glass lined headers the Dominator is built not only to perform efficiently, it's built to last. The Dominator is engineered to outperform the competition with stage-firing, easy set-up and technician friendly service and maintenance through the use of fewer components and effortless accessibility.

## Wide Variety of Venting Options

The Dominator provides added flexibility and ease of installation with multiple venting options and configurations. The sealed combustion chamber minimizes heat loss and requires less clearance from combustible walls.

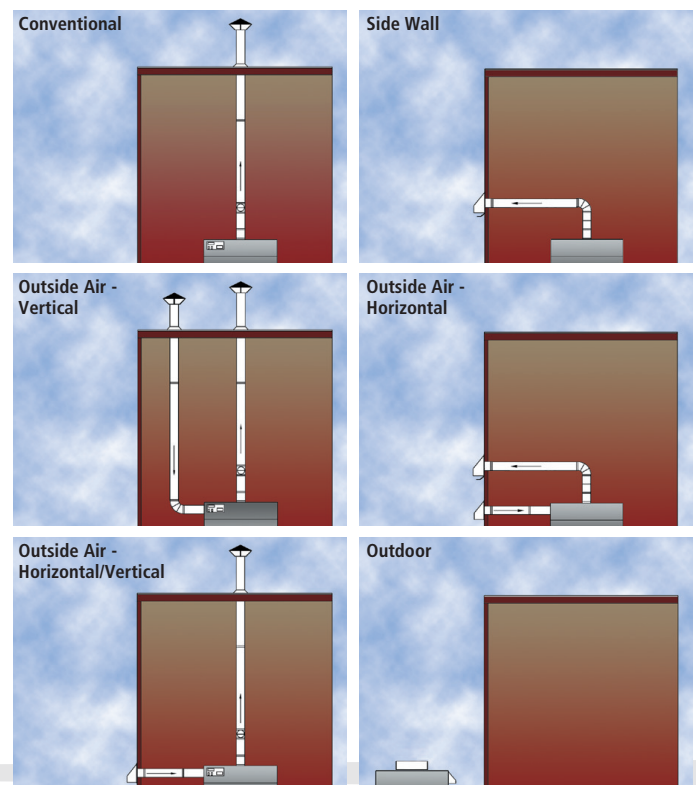





## Rack and Stack

The Dominator offers greater flexibility and ease of installation in a space-saving design that leaves more elbowroom in the mechanical room. A rugged frame and stackable design allow you to install two units in the space of one small footprint.

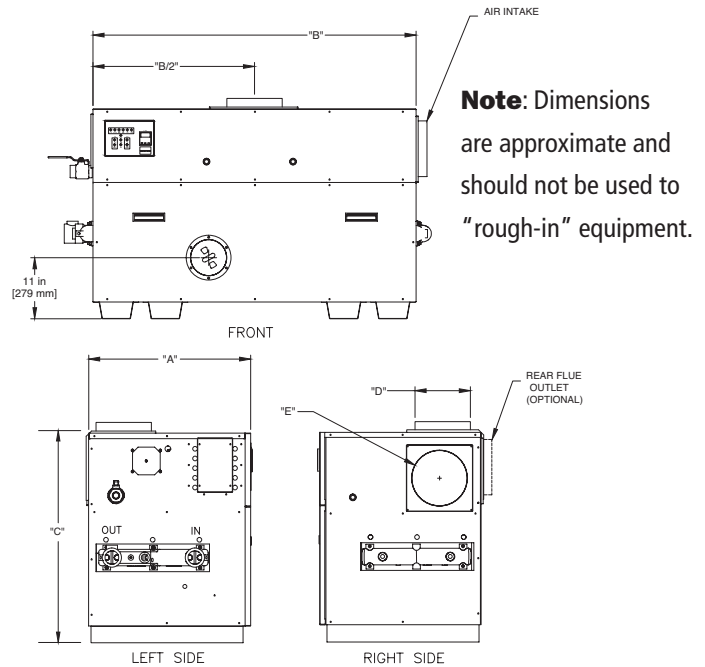

### Models

DB = Boiler

DW = Water Heater

### Dominator Series — Dimensions and Ratings\*

Size	Input		Boiler Output		Length Dim. A		Width Dim. B		Height Dim. C		Flue Vent Dim. D		Ducted Air Dim. E		Shipping Weight	
	MBH	kW	MBH	kW	In.	mm	In.	mm	In.	mm	In.	mm	In.	mm	lbs.	kgs.
300	300	88	251	73	29-5/16	745	22-1/8	562	37-7/8	962	6	152	6	152	512	232
400	399	117	339	99	29-5/16	745	28-5/8	727	37-7/8	962	6	152	6	152	585	265
600	600	176	510	149	29-5/16	745	35-1/8	892	37-7/8	962	7	178	8	203	625	284
750	750	220	638	187	29-5/16	745	41-5/8	1,057	37-7/8	962	8	203	8	203	710	322
900	900	264	765	224	29-5/16	745	48-1/8	1,222	37-7/8	962	10	254	10	254	800	363
1050	1,050	308	893	262	29-5/16	745	58-3/8	1,483	37-7/8	962	10	254	10	254	915	415
1350	1,350	396	1,148	336	29-5/16	745	71-3/8	1,813	37-7/8	962	12	305	12	305	975	442
1500	1,500	440	1,275	374	29-5/16	745	77-7/8	1,978	37-7/8	962	14**	356	12	305	1,015	460
1950	1,950	572	1,658	486	29-5/16	745	97-3/8	2,473	37-7/8	962	14**	356	12	305	1,285	583
2100	2,100	616	1,785	523	29-5/16	745	103-7/8	2,638	37-7/8	962	14**	356	12	305	1,300	590

\* Ratings reflect boilers only. For boiler efficiency information please visit [www.ahridirectory.org](http://www.ahridirectory.org).

\*\* 14" oval to round transition piece.

### Dominator Series Boilers — Temperature Rise/Pressure Drop

Size	15°F		8.3°C		20°F		11.1°C		25°F		13.9°C		30°F		16.7°C		35°F		19.4°C	
	Flow Rate	Pres Drop	Flow Rate	Pres Drop	Flow Rate	Pres Drop	Flow Rate	Pres Drop	Flow Rate	Pres Drop	Flow Rate	Pres Drop	Flow Rate	Pres Drop	Flow Rate	Pres Drop	Flow Rate	Pres Drop	Flow Rate	Pres Drop
	GPM	Ft	ΔL/s	kPa	GPM	Ft	ΔL/s	kPa	GPM	Ft	ΔL/s	kPa	GPM	Ft	ΔL/s	kPa	GPM	Ft	ΔL/s	kPa
300	33.4	0.21	2.1	0.6	25.1	0.12	1.6	0.4	20.0	0.08	1.3	0.2	-	-	-	-	-	-	-	-
400	45.3	0.49	2.9	1.5	34.0	0.29	2.1	0.9	27.2	0.19	1.7	0.6	-	-	-	-	-	-	-	-
600	68.0	1.30	4.3	3.8	51.0	0.76	3.2	2.2	40.8	0.50	2.6	1.5	34.0	0.36	2.1	1.1	-	-	-	-
750	85.1	2.35	5.4	6.9	63.8	1.38	4.0	4.1	51.0	0.91	3.2	2.7	42.5	0.65	2.7	1.9	36.4	0.49	2.3	1.4
900	102.0	3.83	6.4	11.3	76.5	2.25	4.8	6.6	61.2	1.49	3.9	4.4	51.0	1.06	3.2	3.1	43.7	0.80	2.8	2.4
1050	119.0†	6.22	7.5	18.3	89.3	3.65	5.6	10.7	71.4	2.41	4.5	7.1	59.5	1.72	3.8	5.1	51.0	1.29	3.2	3.8
1350	-	-	-	-	114.8†	7.15	7.2	21.1	91.8	4.73	5.8	13.9	76.5	3.38	4.8	9.9	65.6	2.54	4.1	7.5
1500	-	-	-	-	-	-	-	-	102.0	6.29	6.4	18.5	85.0	4.49	5.4	13.2	72.9	3.37	4.6	9.9
1950	-	-	-	-	-	-	-	-	-	-	-	-	110.5†	9.18	7.0	27.0	94.7	6.90	6.0	20.3
2100	-	-	-	-	-	-	-	-	-	-	-	-	119.0†	11.24	7.5	33.1	102.0	8.45	6.4	24.9

† Flow exceeds recommended maximum use a greater temperature rise or consult manufacturer. Cupro-nickel heat exchanger should be considered.

### Dominator Series Water Heaters — Hourly Recovery Capacity ΔT (GPH & LPH)\*\*\*

Size	40°F	22°C	60°F	33°C	80°F	44°C	100°F	56°C	120°F	67°C	140°F	78°C
300	723	2,733	482	1,822	361	1,366	289	1,093	241	911	207	781
400 <sup>1</sup>	1,018	3,853	679	2,569	509	1,927	407	1,541	339	1,284	291	1,101
600	1,486	5,616	990	3,744	743	2,808	594	2,246	495	1,872	424	1,604
750	1,857	7,019	1,238	4,680	928	3,510	743	2,808	619	2,340	531	2,006
900	2,228	8,423	1,486	5,616	1,114	4,212	891	3,369	743	2,808	637	2,407
1050	2,597	9,815	1,731	6,544	1,298	4,908	1,039	3,926	866	3,272	742	2,804
1350	3,339	12,620	2,226	8,413	1,669	6,310	1,335	5,048	1,113	4,207	954	3,606
1500	3,709	14,022	2,473	9,348	1,855	7,011	1,484	5,609	1,236	4,674	1,060	4,006
1950	4,816	18,206	3,211	12,138	2,408	9,103	1,927	7,283	1,605	6,069	1,376	5,202
2100	5,187	19,607	3,458	13,071	2,593	9,803	2,075	7,843	1,729	6,536	1,482	5,602

<sup>1</sup> Model 400 water heater not available for sale in the U.S. market due to DOE regulations.

\*\*\* For water heater efficiency information please visit [www.ahridirectory.org](http://www.ahridirectory.org).



260 North Elm Street, Westfield, MA 01085  
Tel. (413) 564-5515  
[www.rbiwaterheaters.com](http://www.rbiwaterheaters.com)

7555 Tranmere Drive, Mississauga, Ontario L5S 1L4  
Tel. (905) 670-5888



In the interest of product improvement, RBI reserves the right to make changes without notice.