

Turbo-Pak

Two Piece Commercial Finned-Tube

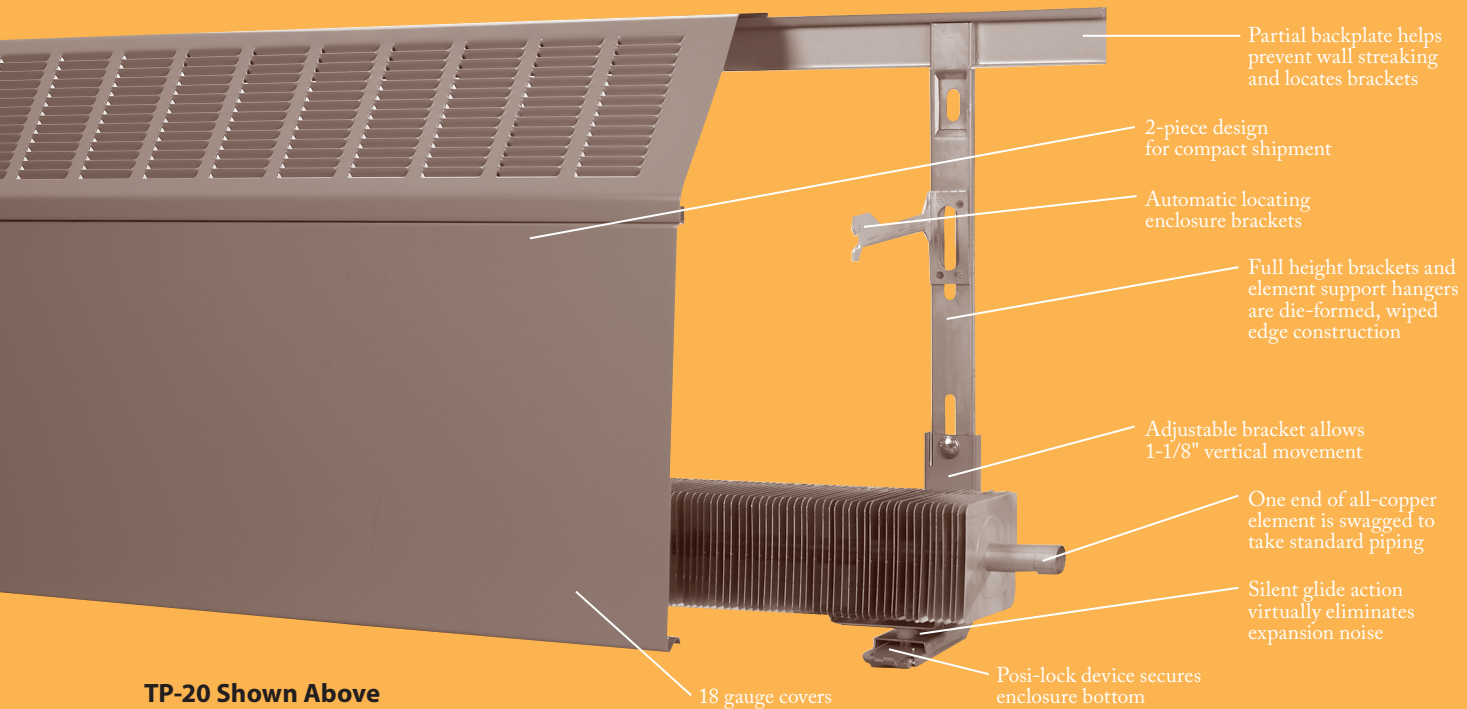

Turbo-Pak



TP-20 Shown Above

Features and Benefits

Easy to buy. Easy to handle. Easy to install.

Turbonics' Turbo-Pak offers two sizes of enclosures, the TP-14, a 14" high two-piece enclosure, and the TP-20, a 20" high, two-piece enclosure which will accommodate two tiers of element. Turbo-Pak's functional slope top design has a pleasing look and enhances the appearance of medical buildings, conference rooms, dining rooms, lobbies, office suites—high traffic areas that demand good looks, durability and low price.

Those contractors familiar with Turbonics products know us for our higher quality products. Turbo-Pak is no exception. Tough, durable 18 gauge covers come with an electrostatically applied, oven-baked prime finish. Partial backplates are rugged 20 gauge prepainted steel. Compare Turbo-Pak with the competition—the same quality just isn't there.

You'll like the wide selection of enclosure and element lengths, too. Standard 14" or 20" high enclosures are packaged in 3, 4, 5, 6, 7 and 8 foot lengths, elements in 2, 3, 4, 5 and 6 foot lengths to save time and keep the job moving. Choice of copper/aluminum or steel elements.

Ships like baseboard



Turbo-Pak's 2-piece design lets us conveniently package all the required components in a single carton. Each carton contains 2-piece enclosure, backplate, brackets, hangers and cradles.

Stores like baseboard



Turbo-Pak's baseboard-like cartons stack one on top of the other. Saves storage space in a garage or warehouse and facilitates loading and unloading trucks and vans. Easy-to-handle cartons protect the enclosures from dents, dings and scratches.

Installs like baseboard



Draw one level chalk line on the installation wall and you're off to the races. Standard bracket is supplied with one or two adjustable element supports that allows a 1-1/8" vertical movement.

All elements are nested onto a slide cradle to support the element tube or pipe. Enclosure brackets, formed at the top, engage the top inside bend of the partial backplate. This exclusive automatic locating design really simplifies installation. The brackets, with posi-lock enclosure locks, snap and secure the enclosure bottom. (See back cover for available accessories.)

Models TP-14 and TP-20

Dimensions and Ratings

ELEMENT CATALOG DESIGNATION	NOMINAL PIPE SIZE	CRADLE NO.	A MIN	A MAX
STC-3/4 435	3/4 (20) COPPER	2	7 3/8 (187)	8 1/2 (216)
STC-435	1" (25) COPPER	2	7 1/2 (191)	8 5/8 (219)
STC-1435	1 1/4 (32) COPPER	2	7 5/8 (194)	8 13/16 (224)
ST-144	1 1/4 (32) STEEL	2	7 7/8 (200)	8 15/16 (227)
ST-243	2" (50) STEEL	1	7 5/8 (194)	8 3/4 (222)

NOTE: Dimensions in "()" are shown in millimeters.

TP-14

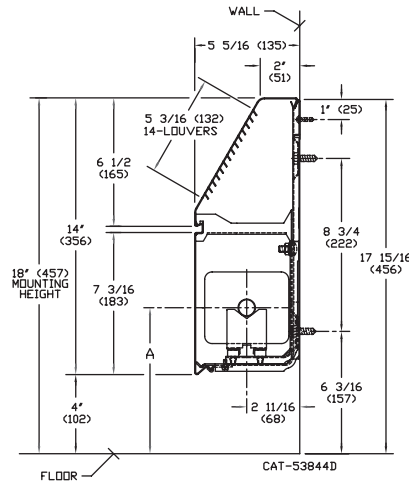

TP-20

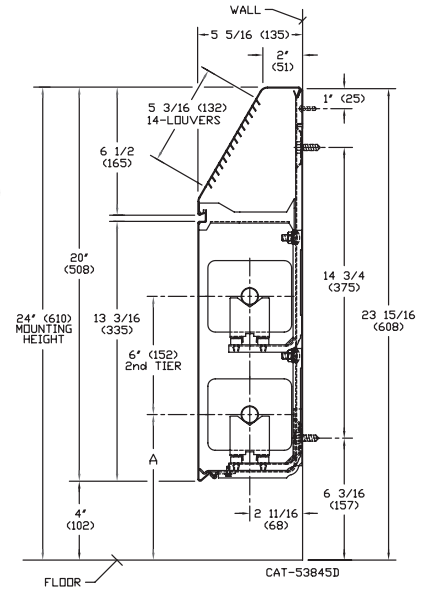

Cover	Tube Size	Catalog Designation	Fin Size (inches)	Fin Per Ft.	Fin Thickness	Enclosure Depth & Height	Tiers & Centers	Mntg. Height	Steam 215° F Factor 1.00	Average Hot Water Temperature °F						
										200°	190°	180°	170°	160°	150°	
										Factor						
											0.86	0.78	0.69	0.61	0.53	0.45
TP-14	1-1/4" I.P.S.	ST-144	4-1/4 SQ.	40	.032" STL	14B	1	18	1570	1350	1230	1080	960	830	710	
	2" I.P.S.	ST-243	4-1/4 SQ.	32	.032" STL	14B	1	18	1400	1300	1080	970	850	740	630	
	3/4" CU.	STC-3/4 435	792Z	50	.020" AL	14B	1	18	1840	1580	1440	1270	1120	980	830	
	1" CU.	STC-435	4-1/4 x 3-5/8	50	.020" AL	14B	1	18	1930	1660	1510	1330	1180	1020	870	
	1-1/4" CU.	STC-1435	4-1/4 x 3-5/8	50	.020" AL	14B	1	18	1860	1600	1450	1280	1130	990	840	
TP-20	1-1/4" I.P.S.	ST-144	4-1/4 SQ.	40	.032" STL	20B	1	24	1670	1440	1300	1150	1020	890	750	
	2" I.P.S.	ST-243	4-1/4 SQ.	32	.032" STL	20B	1	24	1450	1250	1130	1000	890	770	650	
	3/4" CU.	STC-3/4 435	4-1/4 x 3-5/8	50	.020" AL	20B	1	24	2090	1800	1630	1440	1270	1110	940	
	1" CU.	STC-435	4-1/4 x 3-5/8	50	.020" AL	20B	1	24	2180	1870	1700	1500	1330	1160	980	
	1-1/4" CU.	STC-1435	4-1/4 x 3-5/8	50	.020" AL	20B	1	24	2130	1830	1660	1470	1300	1130	960	
TP-20	1-1/4" I.P.S.	ST-144	4-1/4 SQ.	40	.032" STL	20B	2	24	2370	2040	1850	1640	1450	1260	1070	
	2" I.P.S.	ST-243	4-1/4 SQ.	32	.032" STL	20B	2	24	2110	1820	1650	1460	1290	1120	950	
	3/4" CU.	STC-3/4 435	4-1/4 x 3-5/8	50	.020" AL	20B	2	24	2820	2430	2200	1950	1720	1490	1270	
	1" CU.	STC-435	4-1/4 x 3-5/8	50	.020" AL	20B	2	24	2640	2270	2060	1820	1610	1400	1190	
	1-1/4" CU.	STC-1435	4-1/4 x 3-5/8	50	.020" AL	20B	2	24	2510	2160	1960	1730	1530	1330	1130	

- The ratings above include factors shown below for recommended fin mounting height (recommended mounting height is 4" greater than enclosure height).
- Ratings are in BTU per hour per lineal foot of active length. Active fin length is catalog ordering length less 5" for steel, less 4" for copper.
- Water ratings applicable to water flow rates of three or more feet per second have been determined by applying factors to steam ratings.
- Steel fins are painted black. Copper is unpainted.
- NPT threads furnished on steel elements. Please use domestic fittings for proper installation.
- If the unit is to be installed at a different height than recommended, the rating must be adjusted as follows:

Rating multiplied by:

Factor from Table A for the Actual Mounting Height

Factor from Table A for the Recommended Mounting Height

Guaranteed Working Pressures (PSI)

1-1/4" IPS: 660 @ temps. up to 650°F
 2" IPS: 405 @ temps. up to 650°F
 1-1/4" CU: 194 @ temps. up to 300°F
 1" CU: 204 @ temps. up to 300°F
 3/4" CU: 218 @ temps. up to 300°F
 Maximum pressures at other temperatures are available upon request.

Table A

Mounting Height (In.)	18	19	20	21	22	23	24	25	26	27	28	29	30	32	34	36	38	40
Factor 5-5/16" Offset	1.100	1.100	1.100	1.099	1.092	1.085	1.079	1.072	1.065	1.059	1.052	1.045	1.039	1.025	1.016	1.009	1.003	1.000

Accessories



3" End



8" End with Access Door



Inside Corner



Outside Corner



4" and 8" Wall Sleeve



8" Wall Sleeve with Access Door

Turbo-Pak Accessories

Installation Details and Enclosure and Element Shipping Information

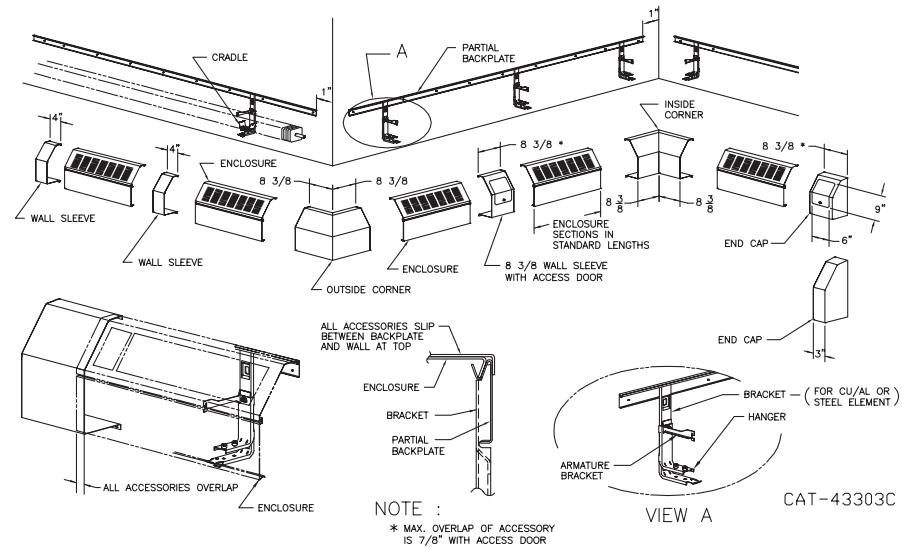

Installation Details

- Standard length: Available from 3' to 8' in 12" increments.
- When two or more enclosures occur in a run, 4" wall sleeve is to be used at joints.

Element and Enclosure Shipping Information

Units with damper assembly are special order. Consult factory for pricing and availability. Element is shipped in separate cartons.

Unit	Catalog Number	Unit Length	Approx. Carton Weight (lbs.)	Package Contents
14" Enclosure Assembly	TP-14-8	8'	36.0	Contains one length each top panel, front panel, partial back plate. 3' through 6' units include 2 brackets, 2 adjustable hangers with hardware, and 2 slide cradles. 7' and 8' units include 3 brackets, 3 adjustable hangers with hardware, and 3 slide cradles.
	TP-14-7	7'	31.5	
	TP-14-6	6'	27.0	
	TP-14-5	5'	22.5	
	TP-14-4	4'	18.0	
20" Enclosure Assembly	TP-14-3	3'	13.5	Contains one length each top panel, front panel, partial back plate. 3' through 6' units include 2 brackets, 4 adjustable hangers with hardware, and 4 slide cradles. 7' and 8' units include 3 brackets, 6 adjustable hangers with hardware, and 6 slide cradles.
	TP-20-8	8'	44.0	
	TP-20-7	7'	39.3	
	TP-20-6	6'	30.8	
	TP-20-5	5'	26.1	
	TP-20-4	4'	21.4	
	TP-20-3	3'	16.7	