



Cabinet Unit Heaters

Steam and Hot Water



CABINET UNIT HEATERS

SELECTION AND "ROUGH IN" MADE EASY - ONLY THE LENGTHS VARY



The Turbonics Cabinet Unit Heater is the industry's most recent design. Years of manufacturing and engineering experience combined with a concern for appearance have resulted in a crisply styled unit that will blend with almost any room decor and provide reliability, durability, individual control and quiet operation.

As unit size increases, only the length changes. The depth and height remain constant, thus allowing the designer to have uniformity of appearance when units of various sizes are installed in adjacent areas.

The wide selection of floor, wall and ceiling units with a variety of air flow arrangements allows for exactly matching design requirements.

The standard 16-gauge front panel is rugged enough to withstand harsh treatment. Exposed cabinetry is provided with a prime coat of neutral eggshell baked enamel, which in many instances can serve as the finish. Back and side panels are 18-gauge.

The pedestal base for floor models is the height of most mop boards.

Field repainting to match the decor is possible and factory applied decorator colors are available as an option.

Recessed models are provided with a field installed wall seal that allows for full or partial recessing depending on the model. The wall seal kit is also available as an option for full or partial recessing of most other models.

The solid state speed control provides infinite variations from high to low speed, giving the occupant finger tip control over fan speed and room temperature.

All Turbonics commercial hydronic products are made from recycled materials. Recycled material contents can be obtained from your local Beacon-Morris representative or by viewing the www.turbonicsinc.com website. Turbonics is a participating member of USGBC-LEEDS.

All units are CSA certified.



TECHNICAL DATA

ALTITUDE FACTORS

Approximate factors for convective heat value at varying altitudes

Altitude	Ferrous Units	Copper Alum. Units
Sea Level	1.000	1.000
1,000 ft.	.984	.969
2,000 ft.	.968	.938
3,000 ft.	.952	.908
4,000 ft.	.936	.878
5,000 ft.	.920	.850
6,000 ft.	.904	.822
7,000 ft.	.889	.795
8,000 ft.	.874	.768
9,000 ft.	.859	.743
10,000 ft.	.844	.718
15,000 ft.	.771	.603
20,000 ft.	.703	.502

Note: The heat output of standard heat distributing units is not affected enough to be considered in sizing the units, when the flow rate has been increased as shown at left. If not increased, apply appropriate heat transfer correction factor indicated.

COIL CAPACITIES OF WATER

Values shown below are decimal equivalent of a U.S. gallon

Unit Size	Standard (One Row Coil)	High Capacity (Two Row Coil)
02	0.208	0.315
03	0.263	0.404
04	0.285	0.448
06	0.351	0.581
08	0.362	0.603
10	0.390	0.660
12	0.428	0.737
14	0.500	0.866

WATER IN OUNCES PER UNIT

Example: If the unit size is 04 with standard coil, then multiply .285 x 128 ounces = 36.48 ounces

†CORRECTIONS WHEN USING GLYCOL SOLUTION IN SYSTEM

		Ethylene Glycol	Propylene Glycol
1. Heat transfer @ 180°F, with no increase in flow rate	20% Solution	.946*	.982*
	30% Solution	.913*	.961*
	40% Solution	.879*	.934*
	50% Solution	.842*	.902*
2. G.P.M. req'd. @ 180°F, (no correction to pump curve)	20°Δ†	114%*	110%*
3. Pump head req'd. @ 180°F, with increase in G.P.M.		123%*	123%*
4. Freezing Point	50% by volume	-37°F	-28°F
	40%	-14°F	-13°F
	30%	+ 2°F	+ 4°F
	20%	+15°F	+17°F

*Compared To Water.

WIRING DIAGRAMS

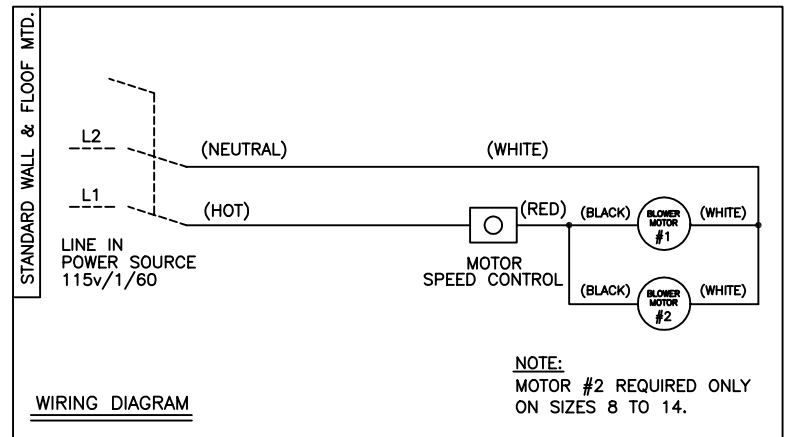

Standard Wall and Floor Units

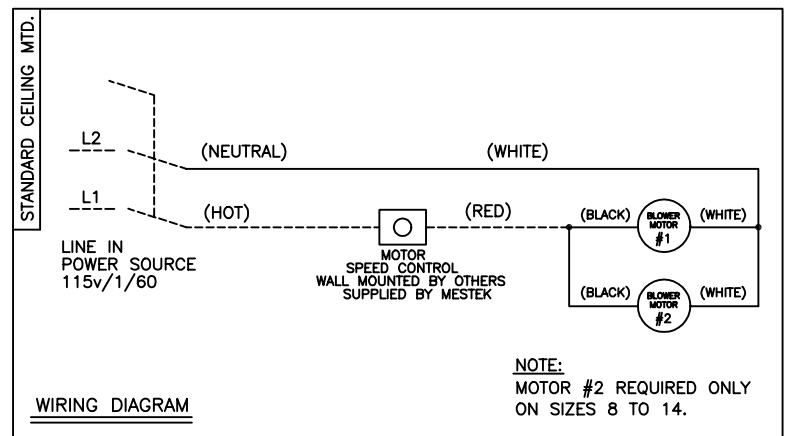

Standard Ceiling Units

SPECIFICATIONS & WARRANTY*

*STANDARD CABINET UNIT ONLY

The contractor shall furnish and install Turbonics Cabinet Unit Heaters as selected to meet or exceed job requirements. The Cabinet Unit Heaters will conform to the items listed below and be certified under CSA guidelines.

CABINETS

All cabinets will be constructed with 18-gauge cold rolled steel, side panels and top. The front panel shall be furnished in 16-gauge cold rolled steel. It will have 1/2", 1-1/2 pound insulation with one side neoprene coated in front of coil. The internal cabinet shall be furnished in 18-gauge galvanized steel. Adequate work area for installation of control valves or electrical equipment shall be provided on both sides of the internal cabinet.

The cabinet shall be provided with a neutral eggshell baked enamel prime coat as standard. (Available if specified) Powder coated baked enamel, color selected from standard.

All cabinets shall be supplied with adjustable rear mounting brackets which will provide adjustment to correct alignment of the unit at installation to non square or out of true walls, joists, studs or surfaces. Adjustable leveling legs (two each base leg) are available when specified.

RECESSED UNITS

All recessed units shall be supplied with a "Wall Seal" assembly. This assembly shall provide protection to the wall or ceiling construction material. The "Wall Seal" shall be supplied in an eggshell baked enamel prime coat as standard. (When specified) Baked enamel colors may be selected from standard.

CEILING MOUNT OR RECESSED UNITS

All "C" and "RC" units shall be supplied with a hinged front panel. The multiple hinges shall provide full swing through 90°. A safety chain shall be provided as standard to prevent the face panel from swinging fully open accidentally. This chain must be easily detached to allow full access for servicing. Speed control switch will be shipped with wiring diagram for installation where desired.

FILTERS

All filters supplied as standard shall be reusable aluminum media with a 69% arrestance level. Filters shall be slide in type which are locked into position with a cotter pin.

FANS

Fan wheels shall be centrifugal, forward curved, double width of electro galvanized steel. Fan housings shall be of formed galvanized sheet metal.

COILS

STANDARD ONE ROW - The durable mechanically bonded copper/aluminum coil presents the best of today's hydronic heating technology. All element assemblies are submersion tested at factory at 250 PSI and are rated at a working pressure of 300 PSI. All units are designed so that field modifications can be made to reverse the coil position if required.

HIGH CAPACITY COIL - This is a hot water coil designed to provide increased capacity when the required load exceeds that of the standard coil for a given size. Its construction is similar to the standard coil however, there are two rows of tubes. Element assemblies are submersion tested at 250 PSI and are rated at a working pressure of 300 PSI.

MOTORS

Standard PSC motors shall have integral thermal protection and start at 78% of rated voltage. Optional PSC High Static motors will be capable of operating in high static conditions up to .4 inches of water column. All motors shall be factory run-tested and assembled in unit prior to shipping. Optional ECM and high static motors will have a solid state control board and a 3 speed switch. All motors shall be factory run-tested and assembled in unit prior to shipping.

ELECTRICAL

All primary internal wiring shall be done at the factory and every unit shall be factory tested for reliability.

FRESH AIR DAMPERS ON DESIGATED UNITS ONLY

When desired specify either of the following:

1. Where noted 25% Manual Outside Air Dampers shall be provided. A manually operated damper quadrant shall provide from 0% to 25% outside air through the use of a single blade damper.

2. Where noted 25% Motorized Outside Air Dampers shall be provided. A synchronous motor (115/60/1) interlocked with the blower shall automatically open the outside air damper when blower starts. The single blade damper shall be adjustable from 0% to 25% outside air. When the blower stops or there is a loss of power, the damper shall return to the closed position. A damper override switch shall be provided to prevent damper operation when desired.

WARRANTY

The products in this catalog are warranted by Turbonics, to be free from defects in material and workmanship for a period of one (1) year from the date of shipment from Turbonics's plant. Turbonics's liability under this warranty is limited to replacing or repairing at our option, F.O.B. our plant any defective component or assembly returned to our factory prepaid and with proper return authorization document. All repairs or replacements are made subject to factory inspection. In the interest of product improvement, Beacon/Morris reserves the right to make changes without notification.